

# SID71 / SID121

Sensor Integration Display

**SICK**  
Sensor Intelligence.



# User manual

## Sensor integration display

UM EN SID xxxx, Revision D

2024-09-05

---

This user manual is valid for:

**Designation**

SID71

SID121

**Order No.**

6084141

6082639

---

# Table of contents

1	For your safety .....	3
1.1	Labeling of warning notes .....	3
1.2	Qualification of users .....	3
1.3	Field of application of the product .....	4
1.3.1	Intended use .....	4
1.3.2	Product changes .....	4
1.4	Licensing information on open-source software .....	4
1.5	Retrieving the source code .....	4
1.6	Security in the network .....	5
2	Overview and ordering data .....	7
2.1	Description .....	7
2.2	Ordering data .....	7
3	Installation .....	9
3.1	Mounting .....	9
3.1.1	Panel mount .....	9
3.1.2	VESA mount .....	12
3.2	Interfaces .....	13
3.2.1	Power connection .....	13
3.2.2	Grounding .....	14
3.2.3	Serial communication .....	14
4	Operation .....	15
4.1	Touchscreen .....	15
4.2	Power LED .....	15
4.3	Display .....	15
5	Maintenance .....	17
5.1	Fuse .....	17
5.2	Battery replacement .....	17
A	Technical appendix .....	19
B	Appendixes .....	23
B 1	List of figures .....	23
B 2	List of tables .....	25
B 3	Index .....	27



# 1 For your safety

Read this user manual carefully and keep it for future reference.

## 1.1 Labeling of warning notes



This symbol indicates hazards that could lead to personal injury.

There are three signal words indicating the severity of a potential injury.

### **DANGER**

Indicates a hazard with a high risk level. If this hazardous situation is not avoided, it will result in death or serious injury.

### **WARNING**

Indicates a hazard with a medium risk level. If this hazardous situation is not avoided, it could result in death or serious injury.

### **CAUTION**

Indicates a hazard with a low risk level. If this hazardous situation is not avoided, it could result in minor or moderate injury.



This symbol together with the **NOTE** signal word warns the reader of actions that might cause property damage or a malfunction.



Here you will find additional information or detailed sources of information.

## 1.2 Qualification of users

The use of products described in this user manual is oriented exclusively to:

- Qualified electricians or persons instructed by them. The users must be familiar with the relevant safety concepts of automation technology as well as applicable standards and other regulations.
- Qualified application programmers and software engineers. The users must be familiar with the relevant safety concepts of automation technology as well as applicable standards and other regulations.

## 1.3 Field of application of the product

### 1.3.1 Intended use

This device is intended for use in industrial environments. The use of peripherals, such as keyboards, memory cards, etc. not suitable for use in an industrial environment is not recommended.

This device is state-of-the-art and has been built to the latest standard safety requirements. However, dangerous situations or damage to the machine itself or other property can arise from the use of this device.

The device fulfills the requirements of the EMC directives and harmonized European standards. Any modifications to the system can influence the EMC behavior.



**NOTE:**

Using hardware not suitable for industrial use (for example, keyboard, mouse, memory card, etc.) in industrial environments may decrease safety of operation. This includes hardware intended for home and office use.

Use industrial-suited USB cables with a maximum length of 2.5 m.



**NOTE: Radio interference (Class A, EN 55032)**

When using the device in residential areas, it may cause radio interference.

Only use shielded serial and Ethernet cables when interfacing to this device.

### 1.3.2 Product changes

Changes or modifications to hardware and software of the device are not permitted.

Incorrect operation or modifications to the device can endanger your safety or damage the device. Do not repair the device yourself. If the device is defective, please contact SICK AG.

## 1.4 Licensing information on open-source software

The operating device works with a Linux operating system. License information for the individual Linux packages can be found in the web-based management of the operating device.

## 1.5 Retrieving the source code

This product contains software components which are licensed by the rights holder as free software or Open-source software under the GNU General Public License, version 2.

SICK AG  
Erwin-Sick-Str. 1  
79183 Waldkirch  
GERMANY  
Subject: Source code SID xxxx

## 1.6 Security in the network



### **NOTE: Risk of unauthorized network access**

Connecting devices to a network via Ethernet entails the danger of unauthorized access to the network.

To prevent unauthorized network access, please read the following notes:

- If possible, deactivate unused communication channels.
- Assign passwords such that third parties cannot access the device and make unauthorized changes.
- Due to its communication interfaces, the device should not be used in safety-critical applications unless additional security appliances are used. Therefore, please take additional protective measures in accordance with the IT security requirements and the standards applicable to your application, e.g., virtual networks (VPN) for remote maintenance access, firewalls, etc., for protection against unauthorized network access.
- On first request, you shall release SICK AG and the companies associated with SICK AG, Erwin-Sick-Str. 1, 79183 Waldkirch, Germany in accordance with §§ 15 ff AktG (German Stock Corporation Act), hereinafter collectively referred to as "SICK AG", from all third-party claims made due to improper use.



## 2 Overview and ordering data

### 2.1 Description

The SID human machine interface (HMI) provides a method to interface with a machine or system, either for control of that machine or to monitor it locally or through a central monitoring system. Various touch screen sizes are available.

#### Features

- PCAP touch interface
- Fanless design
- Dual USB 2.0 ports
- Single 1 Gbps LAN port

### 2.2 Ordering data

#### Products

Description	Type	Order No.	Pcs./Pkt.
Touch panel, 7-inch display	SID71	6084141	1
Touch panel, 12-inch display	SID121	6082639	1

#### Accessories

Description	Type	Order No.	Pcs./Pkt.
Refer to <a href="http://www.Sick.com">www.Sick.com</a>			



## 3 Installation

### 3.1 Mounting

#### 3.1.1 Panel mount

**NOTE:**

Observe the following notes during installation:

When installing the device, leave a gap of at least 30 mm around the device to ensure sufficient air circulation.

When the operating device is installed horizontally, please note that additional sources of heat beneath the operating device may result in heat accumulation.

Make sure to allow sufficient heat dissipation!

Please observe the permissible temperature range specified in the technical data when operating the device.

In order to ensure the degree of protection specified in the technical data, observe the following points:

- A tolerance of  $\pm 0.5$  mm is maintained for the mounting cutout.
- The seal lies flat against the mounting surface.
- The number of mounting brackets, given in the technical data, is used.
- The material of the mounting surface is sufficiently stable to ensure permanently secure attachment of the operating device.
- The mounting surface and the operating device may not become deformed due to the effects of the mounting clamps or through the operation of the device.
- The threaded pins of the mounting brackets are tightened uniformly to a maximum torque of 0.78 Nm.

**Installation**

1. Cut a hole in the enclosure according to the dimensions for the selected display.

Figure 3-1 Panel cutout dimensions

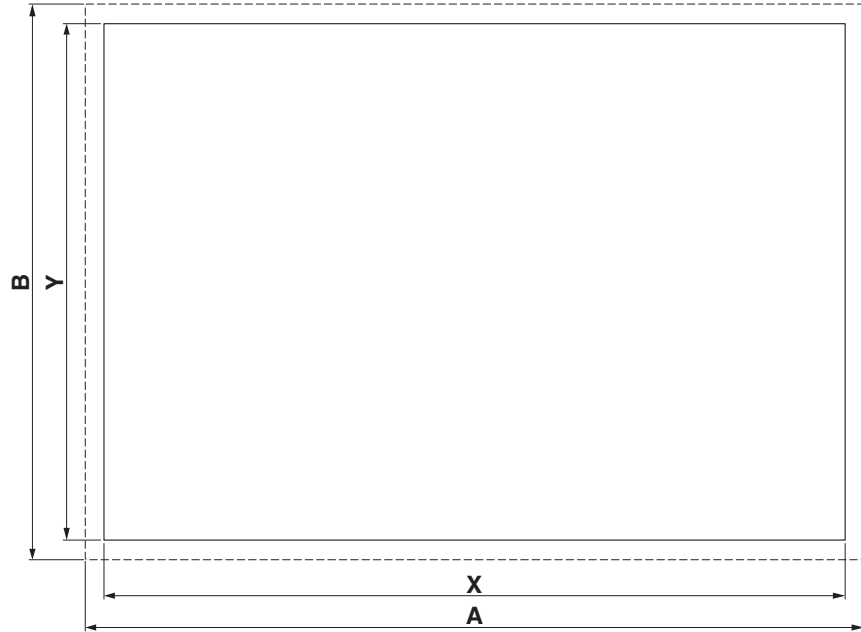

Refer to [Figure 3-1](#) for dimensions

Table 3-1 Overall and cutout dimensions with number of mounting clamps

Display size	Overall dimensions		Cutout dimensions <sup>1</sup>		Number of mounting clamps
	A (mm)	B (mm)	X (mm)	Y (mm)	
7 in.	202	146	195	139	8
12.1 in.	302	229	292	219	10

<sup>1</sup> Cutout dimensions are ±0.5 mm

Figure 3-2 Panel mounting clamps

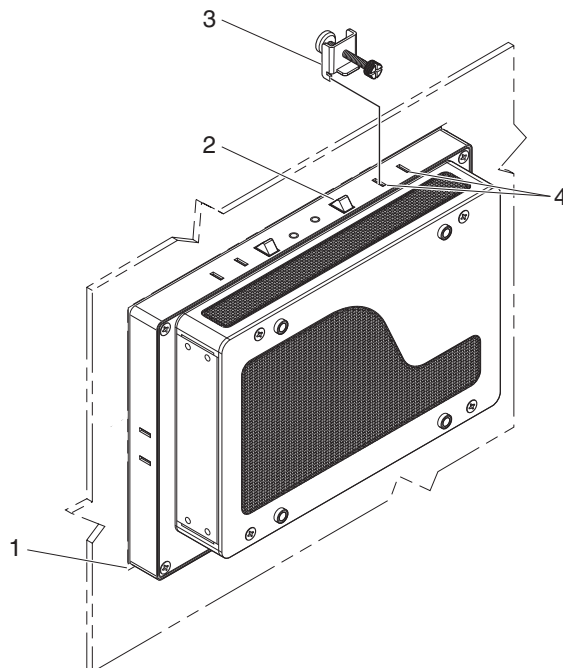

2. From the front, place the bottom edge of the SID in the opening (1), making sure the spring-loaded retention clips (2) are inside the panel. Tilt the top of the SID into the opening until the retention clips are inside the panel. Ensure that the gasket is properly positioned in the groove and against the panel.

**CAUTION:**

All clamps must be installed around the display to secure the SID in the panel (see [Table 3-1](#)). The retention clips on top and bottom of the monitor only provide temporary assistance during installation.

3. From the rear, place the clamps (3) in the slots (4) on the display. Clamps must be installed in every slot.
4. Tighten the screws on all clamps, alternating from one side to the other until the front bezel is secure against the mounting panel. Torque the screws to 0.78 Nm.

**Removal**

1. Remove power and disconnect cables to the SID.
2. Loosen and remove the clamps securing the SID in the panel.
3. Using an assistant, press the retention clips along the top, and tilt the SID forward.
4. Lift the SID so the bottom retention clips clear the panel, and remove.

### 3.1.2 VESA mount

The SID includes a VESA MIS-D, 100, C hole pattern for attachment to an appropriate mount. Note that this standard is for devices up to 14 kg (30 lb.).

Figure 3-3 VESA mount drawing

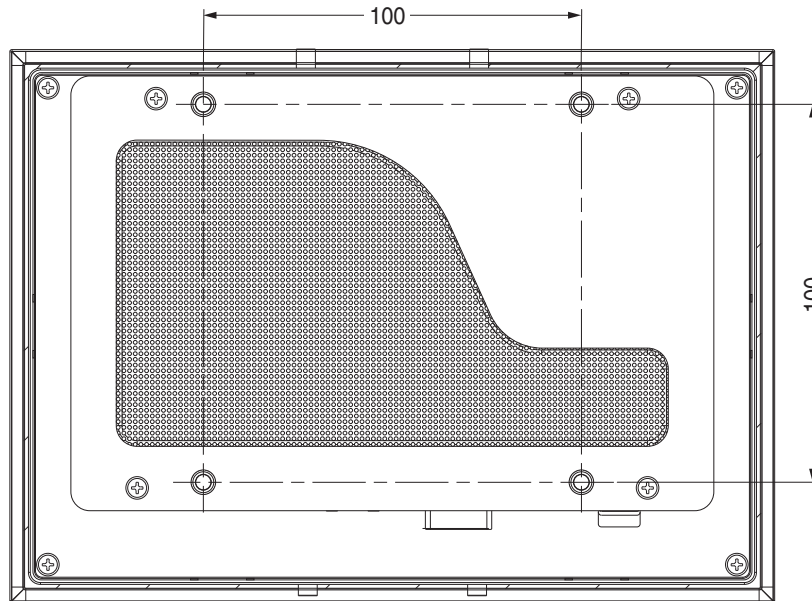

**NOTE:**

Use of a VESA mount invalidates UL listings.

## 3.2 Interfaces

**i** USB, serial, and SD interfaces are only intended for configuration and diagnostic purposes and not for productive operation.

Figure 3-4 Connectors and ports

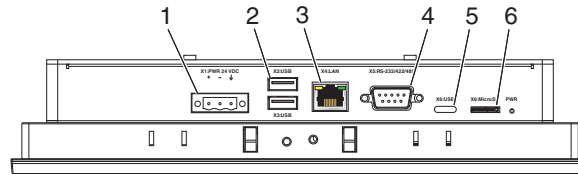

- |   |                    |   |                     |
|---|--------------------|---|---------------------|
| 1 | Power connection   | 4 | D-SUB 9 serial port |
| 2 | USB 2.0 ports      | 5 | USB-C 3.0 port      |
| 3 | RJ45 Ethernet port | 6 | MicroSD card slot   |

After mounting the SID, make any necessary cable connections. The available connectors are:

- USB (USB): Two USB Type A and one USB-C connectors are available. These are for programming and debugging and not for use during operation.
- Network (LAN): An RJ45 connector allows the device to communicate on a 10/100/1000 Base-T Ethernet network.

**i** The use of Cat5e or better LAN cable is recommended.

- Serial port (RS-232/422/485): The serial port may be configured as either RS-232, RS-422, or RS-485 port from within the configuration environment (refer to [“Serial communication” on page 14](#))
- MicroSD: The microSD slot accepts use of a microSD card to transfer data to and from the SID. Typical use is for transferring a common configuration between similar devices.

### 3.2.1 Power connection

Figure 3-5 Power connection

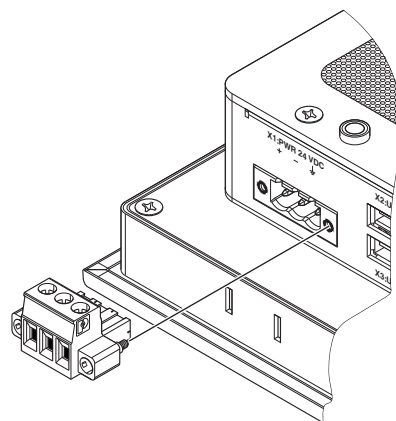

Connect a power source to the three-position removable connector. The connector (Order No. 1777992) accepts wire sizes from 0.2 to 2.5 mm<sup>2</sup> (24 to 12 AWG). Torque the wire-retaining screws in the connector to 0.5 Nm (4.4 lb<sub>f</sub>-in.).

Connect the SID to a 24 V DC power supply.



**NOTE:**

To ensure safe operation, use safety extra-low voltage (SELV) according to DIN EN 61131 as a supply voltage.

This device is protection class I item of equipment.

### 3.2.2 Grounding



Ground and earth are part of the power connector. Both must be connected.

### 3.2.3 Serial communication



The configurable D-SUB 9 port is a future enhancement. It has been included in the document for future reference when the capability is released.

The D-SUB 9 port can be configured to support RS-422, RS-485, or 5-wire RS-232 physical layer signal levels.

- Port 1            RS-232 only
- Port 2            Configurable to RS-232/-422/-485

The function of the pins in the D-SUB 9 connector varies with the different configuration settings.

Table 3-2      D-SUB 9 pinout

D-SUB 9 pin		Function
1	TX+	RS-485 transmitted data plus
2	TXD	RS-232 transmitted data
3	RXD	RS-232 received data
4	RX+	RS-485 received data plus
5	GND	Ground
6	–	Not used
7	–	Not used
8	TX-	RS-485 transmitted data minus
9	RX-	RS-485 received data minus

## 4 Operation

### 4.1 Touchscreen

The device is equipped with a touchscreen. The device is operated using this touchscreen.



**NOTE:**

Pointed or sharp objects, such as pens or fingernails can lead to irreparable damages of the touch screen. Use only fingertips or touchscreen-safe aids for touchscreen operation.

### 4.2 Power LED

A power LED indicates when power is available at the operating device.

Table 4-1 Power LED meaning

Indication	Description
Solid green	Normal operation
Solid red	Supply voltage is outside the operating range
Off	0 V DC

### 4.3 Display



**DANGER:**

If the display is damaged, avoid touching, swallowing, or breathing the liquids or gases which may leak out.



Pixel failures, which can occur with TFT displays, are due to production and are not covered under warranty.

The operating device is equipped with different displays (see technical data) depending on variant.



## 5 Maintenance

### 5.1 Fuse

**NOTE:**  
The semiconductor fuse cannot be replaced.

A semiconductor fuse protects the device. Once the fuse has been tripped, the device must be disconnected from the supply voltage to allow the semiconductor fuse to regenerate. At an ambient temperature of 20°C (68°F), the regeneration takes approximately 20 seconds. The higher the ambient temperature, the longer the regeneration takes.

### 5.2 Battery replacement

The battery can be replaced if it fails.

1. Disconnect power from the SID.
2. Remove the unit from its mounting, either VESA or panel mount, and place it on a flat surface.

**i** Place the SID on a towel to protect the display from damage.

Figure 5-1 Battery replacement

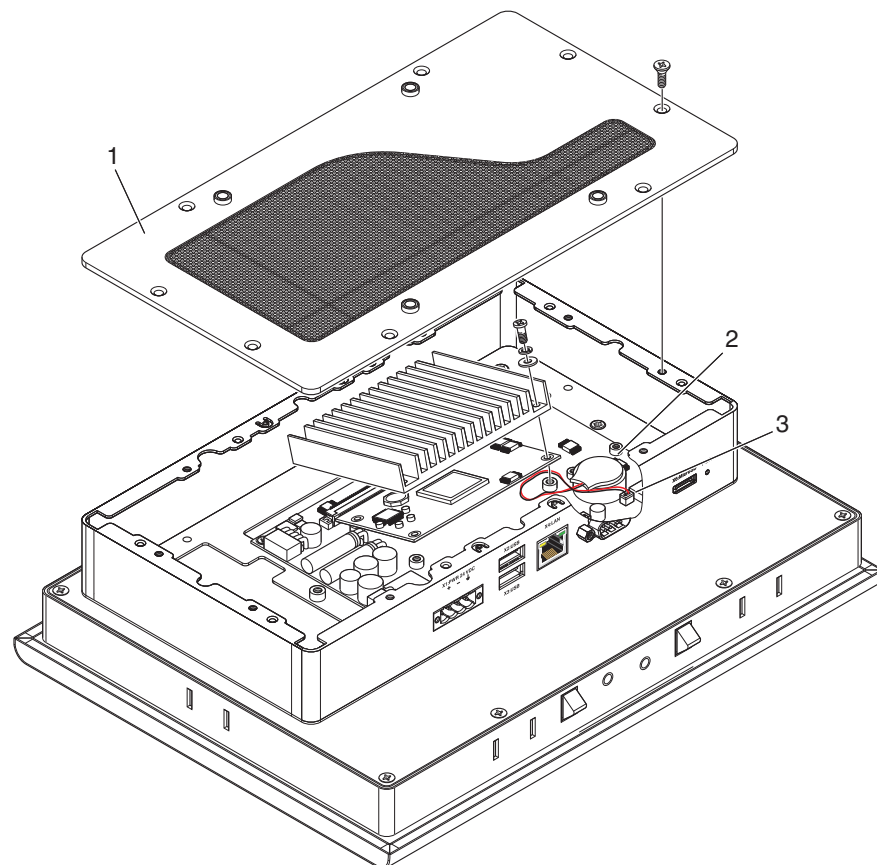

3. Remove the screws securing the back cover (1) and remove the cover.
4. Locate the battery (2) and unplug the battery connector (3).
5. Remove the battery. It is held in place with double-stick tape and may require a small amount of effort to remove.
6. Secure the new battery in place using new double-stick tape (obtained locally).
7. Plug the battery into the circuit board.
8. Place the back cover on the unit and secure with the previously removed hardware. Torque screws to 0.5 Nm.
9. Remount the SID and apply power.

# A Technical appendix

## General data

Overall, dimensions (width x height x depth)*	
SID71	202 x 146 x 51 mm
SID121	302 x 229 x 51 mm
Ambient temperature (operation)	-20 ... 50°C
Ambient temperature (storage/transport)	-25 ... 60°C
Permissible humidity (relative)	5% ... 85%, non-condensing
Weight	
SID71	1.3 kg
SID121	2.5 kg
Degree of protection	IP66 front, IP20 rear
Mounting	Panel cutout
LED indicators	Power, bicolor

\* Dimensions are overall, including bezel

## Electrical data

Power supply, nominal	24 V DC ±20%
Type of connection	Removable screw-type and screw lug
Conductor size	0.2 ... 2.5 mm <sup>2</sup> (24 ... 12 AWG)
Torque, wire clamping screw	0.5 ... 0.6 Nm
RTC battery, typical life	5 years
Fuse	Integrated
Protection against polarity reversal	Diode

## Current and power data

Power consumption, maximum @ 24 V	
SID71	14.71 W
SID121	21.53 W

## Operating systems

Operating system (configuration option)	Linux Yocto
---	-------------

## Data storage

Type	eMMC 8 GB
------	-----------

## Main memory

RAM	4 GB
-----	------

## Processor data

Processor	ARM Cortex-A53
Clock speed	1.6 GHz
Number of cores	4

**Interfaces**

Data port	2x Type A USB 2.0 1x Type C USB 3.0 MicroSD
Serial connection	1x D-SUB 9 (male)
Number of Ethernet connectors	1
Ethernet connection	10/100/1000 Mbps

**Display (SID71)**

Display size, inch (cm)	7 (17.8)
Type	TFT
Resolution, W x H (pixels)	800 x 480
Number of colors	16.7 million
Touch technology	PCAP (10 point)
Brightness (cd/m <sup>2</sup> )	500
Backlight	LED
Backlight MTBF (hours)	50000
Viewing angle (horizontal/vertical)	89°
Panel cutout size, W x H (mm)	195 x 139

**Display (SID121)**

Display size, inch (cm)	12.1 (30.7)
Type	TFT
Resolution, W x H (pixels)	1280 x 800
Number of colors	16.7 million
Touch technology	PCAP (10 point)
Brightness (cd/m <sup>2</sup> )	500
Backlight	LED
Backlight MTBF (hours)	50000
Viewing angle (horizontal/vertical)	88°
Panel cutout size, W x H (mm)	292 x 219

**Mechanical tests**

Impact load, shock test	IEC 60068-2-27
Sinusoidal vibration	IEC 60068-2-6

**Conformance with EMC directives**

EN 61000-6-4, Class A	
EN 61000-6-2	

**Approvals**

CE compliant

IEC 61131-2

UL 50E Type 4



---

## B Appendixes

### B 1 List of figures

#### Section 3

Figure 3-1:	Panel cutout dimensions .....	10
Figure 3-2:	Panel mounting clamps .....	11
Figure 3-3:	VESA mount drawing .....	12
Figure 3-4:	Connectors and ports .....	13
Figure 3-5:	Power connection .....	13

#### Section 5

Figure 5-1:	Battery replacement .....	17
-------------	---------------------------	----



## B 2 List of tables

### Section 3

Table 3-1:	Overall and cutout dimensions with number of mounting clamps .....	10
Table 3-2:	D-SUB 9 pinout.....	14

### Section 4

Table 4-1:	Power LED meaning.....	15
------------	------------------------	----



---

**B 3 Index**

<b>B</b>		<b>R</b>	
Battery replacement.....	17	Removal.....	11
<b>C</b>		<b>S</b>	
Cutout dimensions .....	10	Safety.....	3
<b>D</b>		Serial communication.....	14
Display .....	15	Source code.....	4
D-SUB 9 pinout .....	14	<b>T</b>	
D-SUB 9 port.....	14	Touchscreen.....	15
<b>F</b>		<b>U</b>	
Fuse.....	17	USB .....	13
<b>G</b>		<b>V</b>	
Grounding .....	14	VESA mount .....	12
<b>I</b>		<b>W</b>	
Installation.....	9	Warning notes.....	3
Interfaces .....	13		
<b>L</b>			
Licensing.....	4		
<b>M</b>			
Maintenance .....	17		
MicroSD .....	13		
Mounting .....	9		
<b>O</b>			
Operation .....	15		
Ordering data .....	7		
<b>P</b>			
Panel mount.....	9		
Power connection .....	13		
Power LED .....	15		
<b>Q</b>			
Qualifications .....	3		

